

Standardized Surface Sampling Methods for Metals

Kevin Ashley, Ph.D.

*U.S. Department of Health and Human Services
Centers for Disease Control and Prevention
National Institute for Occupational Safety and Health
Cincinnati, Ohio (USA)*



Disclaimers

Mention of company names or products does not constitute endorsement by the Centers for Disease Control and Prevention.

The findings and conclusions in this report are those of the author and do not necessarily represent the views of the National Institute for Occupational Safety and Health.



Overview



Background

- Reasons for surface sampling
- Comparison to action levels or background

Surface sampling techniques

- Wipe, dermal, vacuum, etc.
- Attributes & limitations
- Available research & data gaps

Discussion & summary

- Performance data available (presented later)
- Examples of standardized methods
- Recommendations / improvements



Introduction

Why Surface Sampling? Examples:

- Evidence of skin sensitization by exposure to beryllium particles
- Ingestion of lead from surface particles on hands
- Take-home exposures to metals in dust
- ⇒ Prevent exposure to metals on surfaces through exposure monitoring



Surface Action Levels for Pb, Be

Few metals have surface action levels established by regulatory agencies.

Lead and Beryllium are two elements having surface dust loading limits in the US.

Pb: EPA; Be: DOE



Beryllium surface compliance levels (DOE: 10 CFR 850)

Equipment release:

0.2 $\mu\text{g Be}/100 \text{ cm}^2$

Housekeeping:

3.0 $\mu\text{g Be}/100 \text{ cm}^2$



(But no information on sampling methodology)

⇒ “Analysis by AIHA-accredited lab or equivalent”



Surface action levels for lead [40 CFR 745 (EPA 403 Rule), 2001]

Definition of dust-lead hazard (§745.6)

- floors (bare or carpeted): 40 $\mu\text{g}/\text{ft}^2$
- window sills (interior): 250 $\mu\text{g}/\text{ft}^2$

Clearance levels (§745.227)

- floors (bare or carpeted): 40 $\mu\text{g}/\text{ft}^2$
- window sills (interior): 250 $\mu\text{g}/\text{ft}^2$
- window troughs: 400 $\mu\text{g}/\text{ft}^2$



EPA 403 Rule Pb Samples:

Samples of settled dust for risk assessment or clearance shall be collected:

- from horizontal surfaces underneath friction surfaces
- from floors (bare & carpeted)
- from interior window sills
- from window troughs (clearance only)
- *using wipes that meet ASTM E1792*



Definition of Wipe Sample (40 CFR Part 745, §745.63):

Wipe Sample means a sample collected by wiping a representative surface of known area, as determined by ASTM E1728 [sample collection standard practice], or equivalent method, with an acceptable wipe material as defined in ASTM E1792 [Pb wipe specification].



EPA 403 Pb samples, cont'd.

All samples shall be analyzed by a laboratory recognized under the National Lead Laboratory Accreditation Program (NLLAP).

[40 CFR 745.227(f)(2)]



Surface sampling of metals

Consider:

Wipe samples (wet, usually)

Vacuum samples (various techniques)

Swab sampling (rare for metals)

Tape samples

Rinsates



Surface sampling of metals, cont'd

- Hard / smooth / nonporous surfaces
- Soft / rough / porous substrates
- Fragile substrates
- Oily / grossly contaminated surfaces
- Dermal sampling
- Bulk sampling



Surface Sampling Techniques

- *Wipe sampling*
Wet: consider wetting agent
Dry: consider sampling medium
- *Vacuum sampling*
Alternative to wipe sampling
Consider substrate to be sampled



Dermal & Bulk Sampling

- *Dermal sampling*
Wipe, patch, tape & rinse methods
- *Bulk sampling*
Use if there is gross dust buildup
Soils / sediments



National Technology Transfer and Advancement Act of 1995 (NTTAA)

Public Law 104-113 (enacted 1996); directs federal agencies to:

- (A) Use voluntary consensus standards in lieu of in-house procedures
- (B) Participate in the development of relevant voluntary consensus standards



Advantages of the consensus standards development process

- Brings together people with a diversity of backgrounds, expertise, and knowledge
- Provides a balanced representation of interests at the standards-writing table (users, producers, general interest)
- Quality is enhanced by strict balloting and due process procedures, and requirements for method precision and bias / uncertainty statements
- Working group format promotes open discussion

ASTM International wipe sampling standard for metals

ASTM D6966,
Standard Practice for
Collection of Settled Dust
using Wipe Sampling
Methods for Subsequent
Determination of Metals

(Note: Established by voluntary
consensus)



ASTM D6966 Requirements

- ⇒ Individually packaged wipes; non-interfering materials; minimal metals background
- ⇒ >75% collection efficiency (RTI, 1990s)
- ⇒ Sampling scheme (100-cm² minimum sampling area):

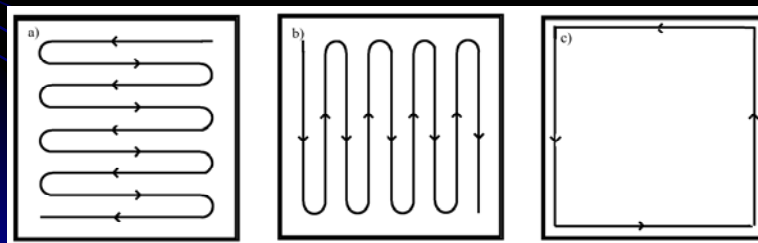

ASTM E1792 Wipe Specifications

- Minimal background lead
- Ruggedness testing
- Uniform moisture content
- Individually packaged
- Dimensions & thickness
- Pb collection efficiency/ recoverability tests



⇒ Dry sampling methods



Vacuum cleaner method (carpets)
• ASTM D5438

Micro-vacuum sampling (rough /
fragile / inaccessible surfaces)
• ASTM D7144



Dry wipe sampling (special cases)
• ASTM D7296

Bulk sampling
• ASTM & EPA methods

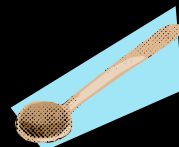

Vacuum sampling: Consensus standards



ASTM D7144



ASTM D5438

Dry wipe sampling

- ASTM D7296, Standard Practice for Collection of Settled Dust Samples using Dry Wipe Sampling Methods for Subsequent Determination of Beryllium and Compounds
- ⇒ Use *only* if wet wipe sampling or vacuum sampling inappropriate
[Also may be applicable to sampling radioactive elements]



Dermal sampling methods

1. Wet wipe
2. Patch sampling
3. Tape sampling
4. Skin rinsates



(Photo by Dr. A. L. Sussell)



Surface sampling stds for metals (gov't & consensus)

Method	Media / device	Surfaces
OSHA ID-125G & ID-206	Wet or dry filter or wipe	Smooth / Hard; Dermal
NIOSH 9100, 9102	Wet wipe	Smooth; Dermal
ASTM D6966	Wet wipe	Smooth / Hard
ASTM E1216	Adhesive tape	Smooth
OSHA & NIOSH (several)	Patch or Rinse	Dermal samples
ASTM D5438	Vacuum cleaner	Carpets
ASTM D7144	Micro-vacuum	Rough or fragile
ASTM D7296	Dry wipe	Oily or fragile

ASTM D5438 – High-volume vacuum sampler (HVS3)

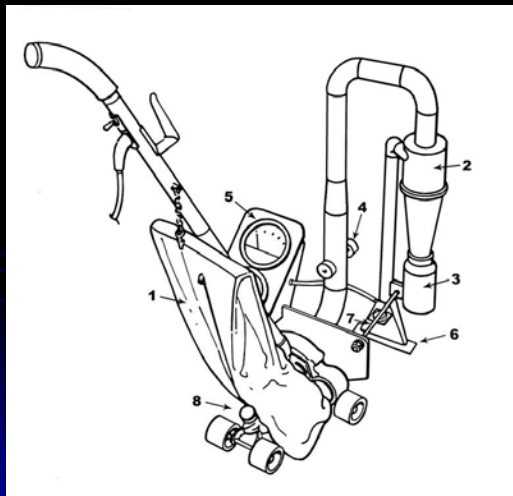

Dust sample collected
in catch bottle (part #3)



(Figure courtesy of
Dr. R. G. Lewis)



ASTM D7144 Micro-vacuum sampler evaluation (Ashley et al., JOEH 2007)

Main sampler components:

- Collection nozzle
- Cassette (& filter)



Dermal sampling: Need for voluntary consensus standards

- Recent review articles demonstrate lack of harmonization & consequent difficulty in data comparisons between different dermal exposure studies.
- ⇒ New working groups in ISO TC 146 / SC 2 and ASTM International D22.04 will develop standardized procedures for dermal sampling.



Bulk sampling methods

- Many published ASTM standard procedures: Scooping, coring; penetrometers, augers, etc. (www.astm.org)

See, e.g.:

(a) J.H. Morgan, Ed., *Sampling Environmental Media*; ASTM STP 1282 (1996)

(b) EPA/OSW, *RCRA Waste Sampling Draft Technical Guidance* [EPA 530-D-02-002] (2002)

- ⇒ Sample surface vs. subsurface: Distinguish anthropogenic vs. natural sources of elements.

Surface sampling of nonmetals

Recognize that other surface sampling methods for non-metals have been published by gov't and consensus standards groups; Examples:

- Drugs / pharmaceuticals
- Pesticides
- Biological agents



Summary

Focus here has been on available governmental and *voluntary consensus standards* for sampling of metals on surfaces, esp. wipe & vacuum collection methods.

- Performance data support some of the consensus standards (to be presented later).
- Bulk sampling methods are available (ASTM International; EPA) & well standardized.
- ⇒ Identified need for standardization of dermal sampling methods (ISO, ASTM).

Acknowledgments

ASTM International Subcommittee D22.04 on
Workplace Air Quality

ASTM International Subcommittee E06.23 on
Mitigation of Lead Hazards

Beryllium Health and Safety Committee, Sampling
and Analysis Subcommittee

