

Next-generation metal analyzers based on nanomaterials for biomonitoring and environmental monitoring

NIOSH DREAM Methods Workshop Session 6: Surface Sampling/Biomonitoring

November 13-14th, 2008

Wassana Yantasee, PhD, MBA
Pacific Northwest National Laboratory, Richland, WA
Materials Chemistry and Surface Research Group
Wassana.Yantasee@pnl.gov

Goal

- ▶ **Goal:** To develop portable metal analyzers for biomonitoring and environmental monitoring of toxic metals
- ▶ **Targets:** Cd, Pb and Hg
- ▶ **Matrices:** Urine, saliva, blood, natural waters
- ▶ **Relevant range:** 0 to 100 ppb ($\mu\text{g/L}$)
- ▶ **Characteristics of next-generation metal analyzers:**
 - Are portable, field-deployable, and programmable
 - Require no sample pretreatment and are user friendly
 - Require short analysis time (3-5 min)
 - Are affordable and consume low power
 - Are able to detect multiple metals at once and as accurate as gold-standard ICP-MS
- ▶ **Sponsors:** CDC/NIOSH, NIH/NIEHS, DOE-EMSP

Current state of metal analyzers

- ▶ ICP, ICP-MS, AAS are not portable, expensive, require samples to be sent to lab, and require trained personnel to operate
 - Lengthy turn around time for sample analysis (2-4 weeks)
 - \$50-\$100 per sample (per metal)
- ▶ Real-time analyzers are desirable (e.g., for timely removal of workers from hazardous conditions)
- ▶ On-site, affordable analyzers will enable better and more frequent monitoring of worker exposure by employers
- ▶ Available portable systems:
 - Portable XRF is not yet sensitive (in ppm or mg/L)
 - Chemical spot test kits are not quantitative
 - LeadCare systems are only for blood Pb
 - SafeGuard™ arsenic analyzer (based on ASV, only works waters, \$35K a unit, 30min/sample, interfered by Cu)
 - Metal biosensors (using antibody to identify metals, 6-8 hrs/analysis)

Electrochemical sensors for metal analysis

Issues of current electrochemical sensors:

- Most rely on Hg for metal preconcentration
- Chemically modified sensors (Hg-free) rely on
 - Addition of soluble ligands to samples (risk adding metal contaminants)
 - Ligands that are loosely immobilized on electrodes and depleted over time
 - Some use gold (metal peaks overlap), silver (small operating window), and bismuth (unstable film) electrodes
- All suffer from fouling by proteins, surfactants, and organic molecules (they adsorb on sensor surface and form insulating layer → low signal)
- Metals are readily bound to proteins and can't be detected accurately
- Most need sample pretreatment (e.g., acid digestion or extraction) to release metals from proteins and to prevent electrode fouling

Our approach

1. Electrochemical sensors meet criteria for next-gen metal analyzers
2. Use novel sorbents to preconcentrate metals
 - must be able to compete with proteins for metals in urine
 - must have selectivity for target metals over non-target metals
 - ligands are covalently bound with substrate first (no ligand depletion)
3. Use Nafion polymer binder
 - Nafion immobilizes sorbents on sensor surface,
 - Nafion also prevents fouling (prevents protein adsorption and forming insulating layer)

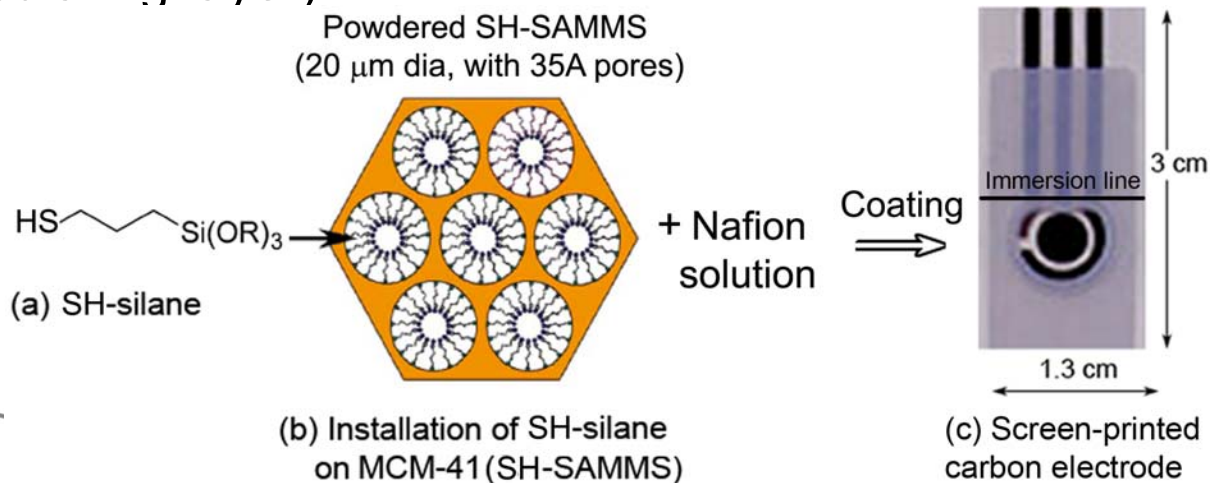

Two classes of nanomaterials: Functional silica (SAMMS) and magnetic nanoparticles (NPs)

Complexation Site

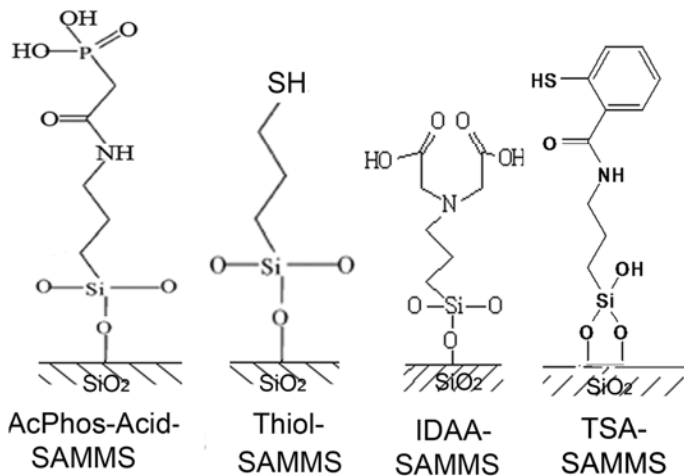

High affinity ligands

⇒ Surface Monolayer

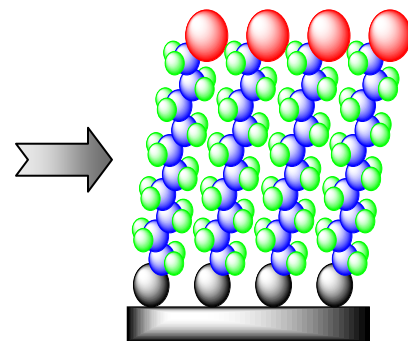

High capacity

⇒ Ordered Porosity

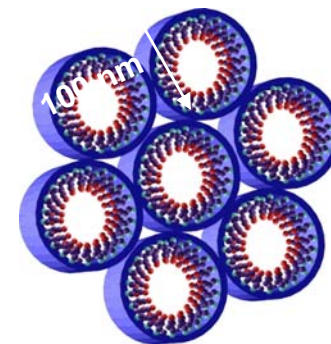

High surface area silica

Or



High surface area mag nanoparticles

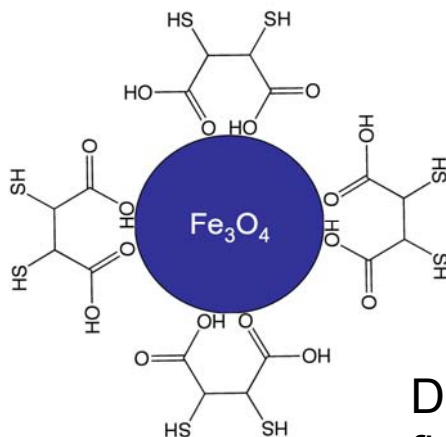

DMSA-NP

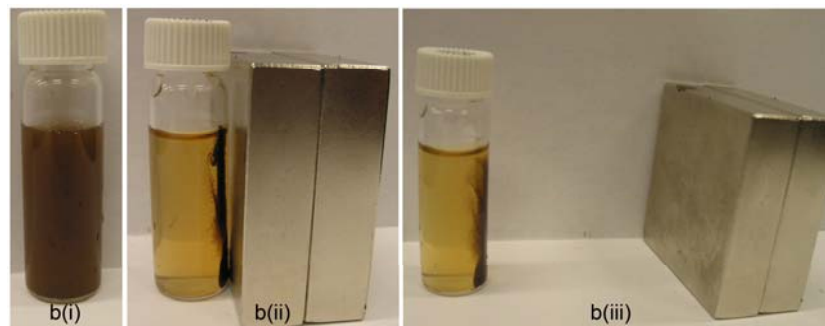

DMSA-NPs only turn magnet under magnetic field and can be removed out of solution

Yantasee et al., *Env Sci Technol*, 2007, 41, 5114

Our research focus:

Functional nanomaterials for medical applications

Current projects employing advanced nanomaterials:

- ▶ At biomonitoring tools for worker exposure to heavy metals (CDC/NIOSH)
- ▶ For chelation therapies of heavy metals (NIH/NIEHS)
- ▶ For actinide decorporation in the event of dirty bomb (NIAID/Project BioShield)

New area:

- ▶ Sorbent dialysis (next-gen personal dialysis devices): to reduce dialysate from 120 L to < 1 L

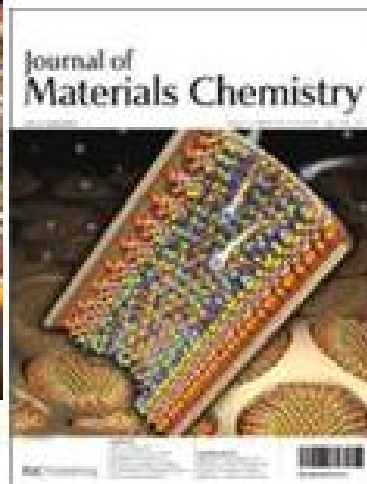
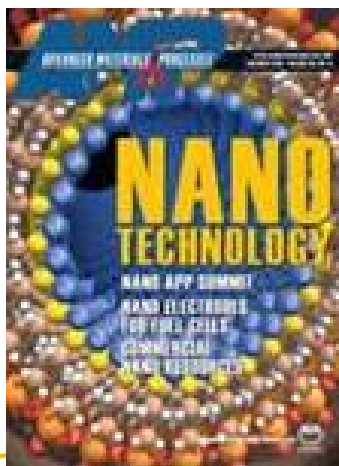
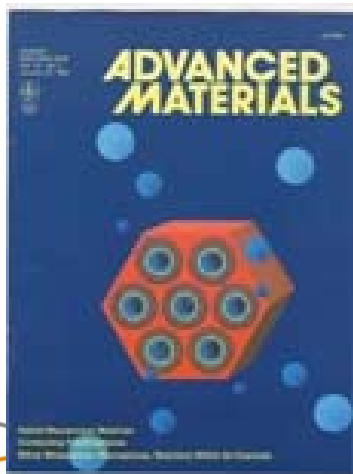
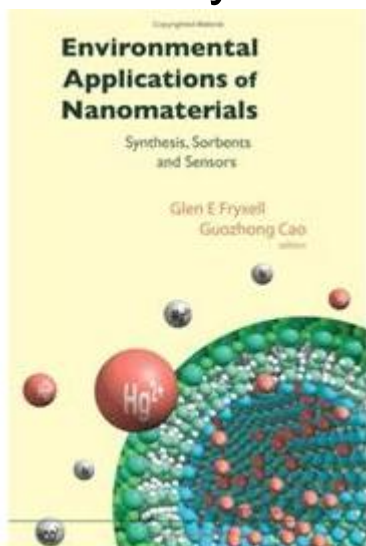

PNNL's SAMMS made covers of journals and book

Sensor platforms:

Nanoparticles are immobilized onto electrode surface for metal preconcentration

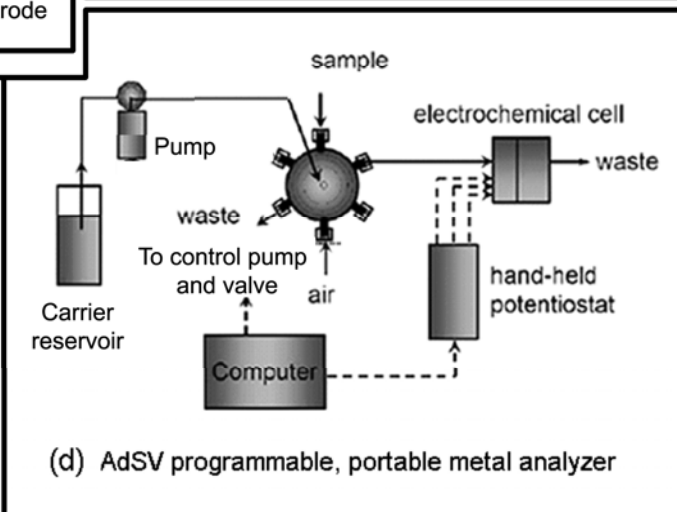
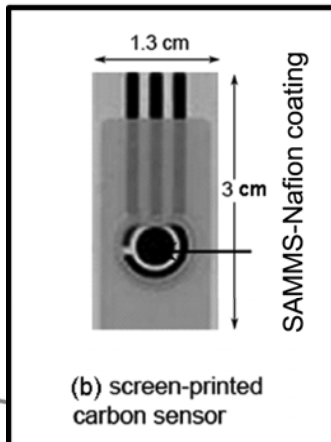
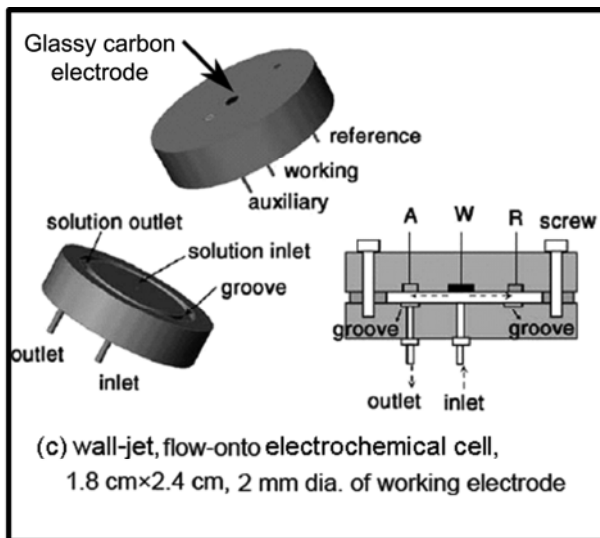
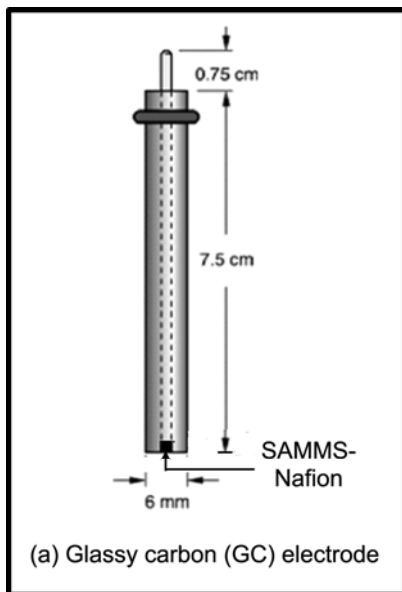

3 platforms are used at PNNL

- (a) Rod electrode for batch measurements
- (b) Disposable electrodes for screening test
- (c) Flow cell electrode
- (d) Integration of flow cell electrode into an automated device

Yantasee et al., *EHP*, 2008, 115, 1683.

Detection principle: Two-step process

1. **Preconcentration step:** SH-SAMMS (coated on electrode tip) binds with metal ion (e.g., Pb(II)) by complexation (e.g., with -SH group). 1-3 min in samples

2. **Detection step:**

2.1 Transfer the electrode to 0.1 M HCl. Accumulated Pb(II) is desorbed

2.2 A -1.0V is applied immediately to convert Pb(II) to Pb(0) on electrode. 1 min

2.3 Pb(0) is subsequently detected by an anodic stripping voltammetry:



Pb(II) do not re-bind to SH-SAMMS in acid, so the sensor does not need cleaning

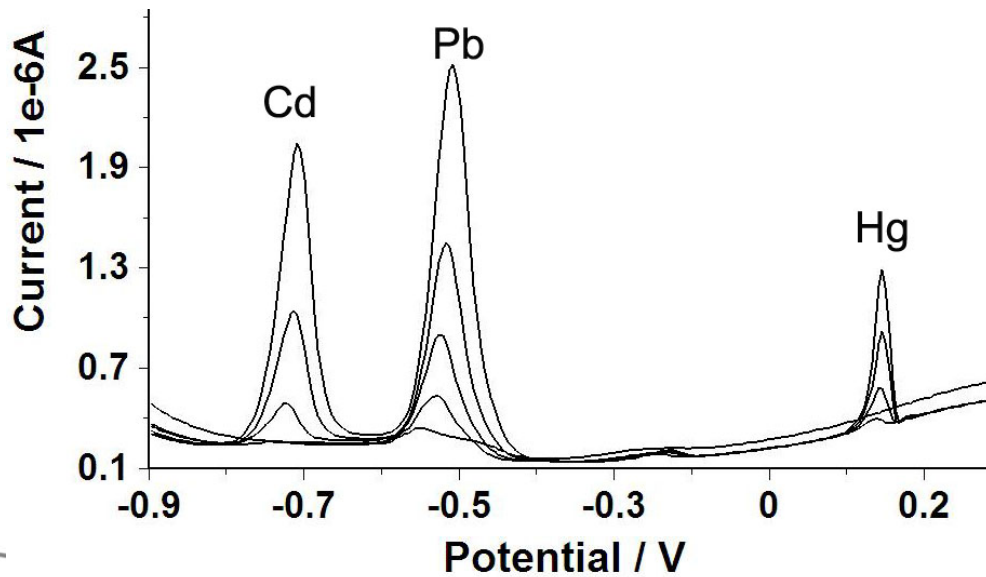

➤ **Peak height** is proportional to metal concentration in solution

➤ **Peak position** identifies what metal:

- Cd at -0.7V
- Pb at -0.5V
- Hg at 0.2V

▲ Detection of 10-100 ppb Cd/Pb, and 20-200 ppb Hg in river water at a SAMMS-Nafion electrode

SAMMS-Nafion sensors

- SAMMS: created at PNNL for environmental applications (toxin removal)
- SAMMS: created by attachment of organic molecules on mesoporous silica
- Large surface area ($> 500 \text{ m}^2/\text{g}$) \rightarrow large capacity (600 mg Hg/g material)
- Organic ligands of SAMMS have been fine-tuned for heavy metals (Pb, Cd, Hg), lanthanides (Eu, Nd, Lu), actinides (Pu, Am, U), chromate, arsenate, etc.
- Take advantage of:
 - SAMMS as outstanding metal preconcentrator +
 - Nafion as antifouling binder
 - SAMMS + Nafion is coated on electrode surface
 - 30 min air-dried to make rigid, stable, and porous film
- When coated with SAMMS-Nafion film, disposable sensor can last all day in urine
- The detection limits are improved by 1000-fold

Journal of
Materials Chemistry



Example detection using SAMMS sensors

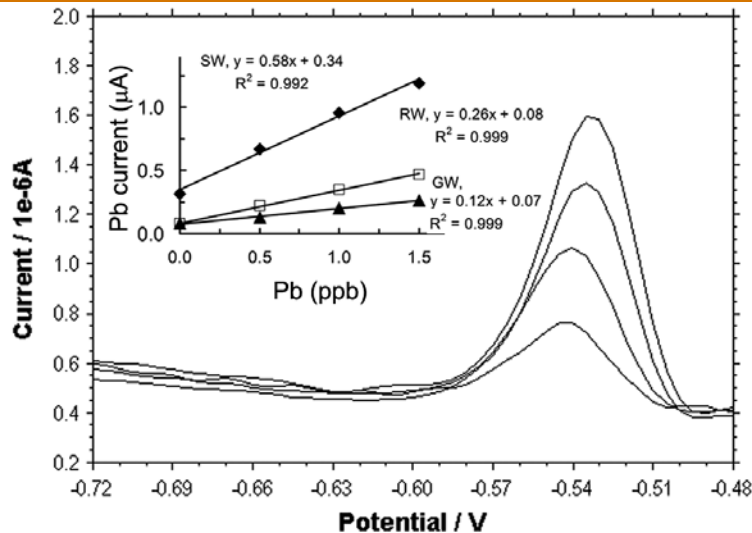

- 0-1.5 ppb of Pb in river, ground, and sea waters can be detected quantitatively
- No need for sample pretreatment (no filtration or pH adjustment)
- EPA's drinking water = 15 ppb Pb

▼ Both methyl-Hg (a) and Hg^{2+} (b) can be detected at SAMMS-Nafion sensor

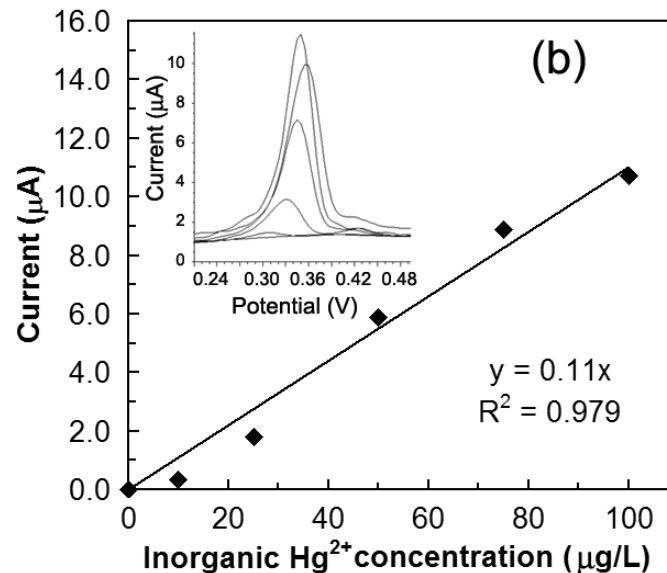
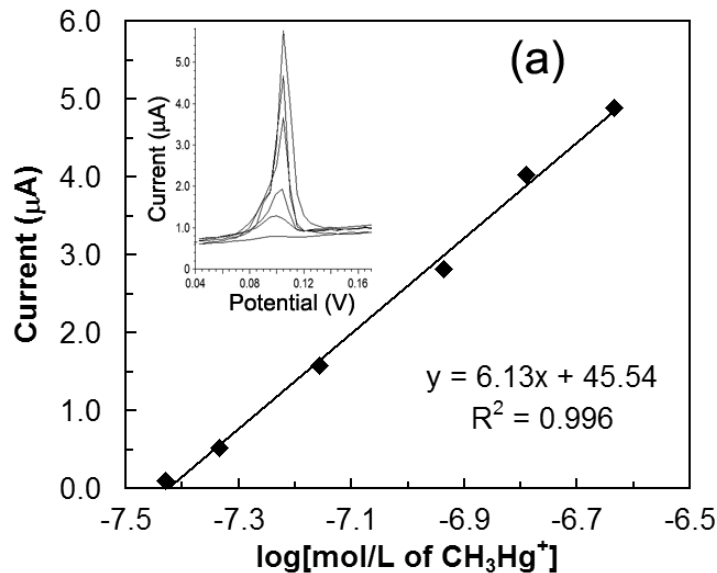

Example detection of SAMMS sensors

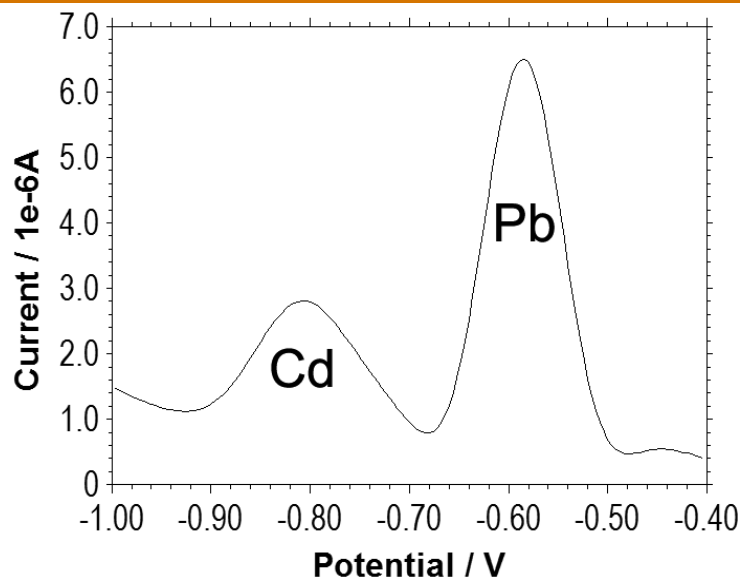
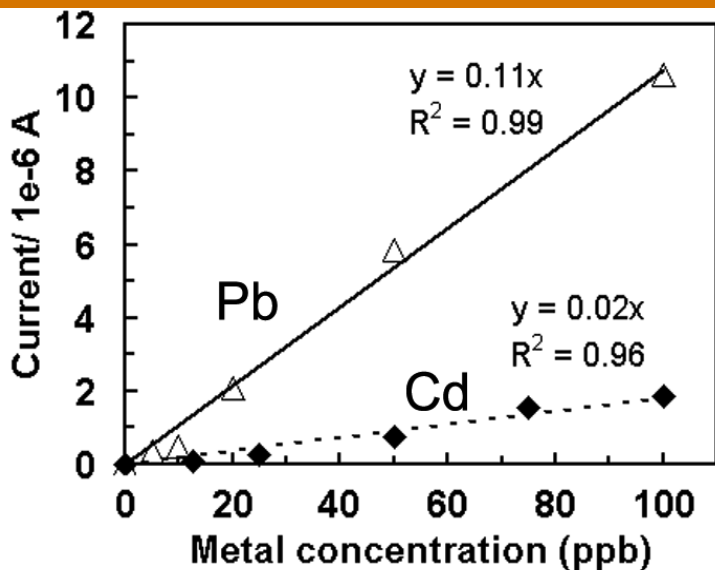

▲ Pb and Cd could be detected simultaneously in urine without pretreatment

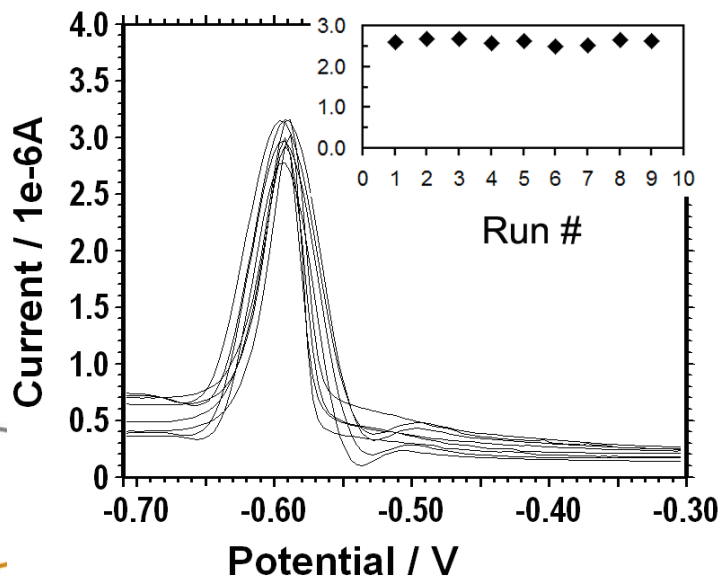

▲ **Excellent reproducibility in urine:**
%R.S.D = 2.6 (9 consecutive measurements of 50 $\mu\text{g/L}$ Pb in human urine) at a SAMMS-disposable sensor

→ same with gold standard ICP-MS

Magnetic and electromagnetic sensors

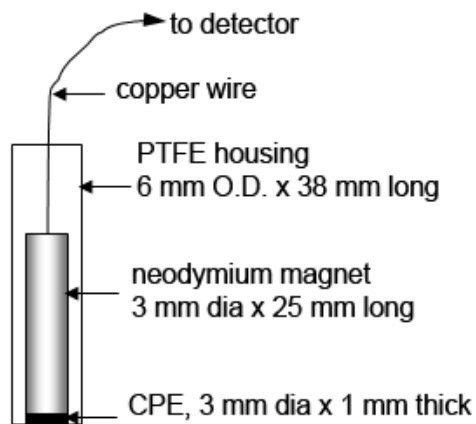

(a) Magnetic electrode

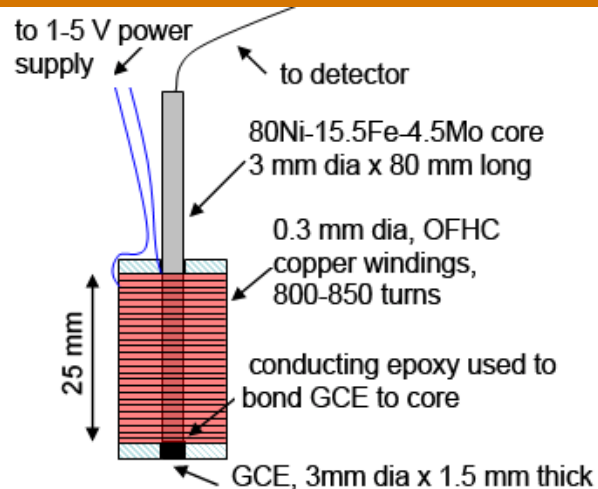

(b) Electromagnetic electrode



(c) DMSA- Fe_3O_4

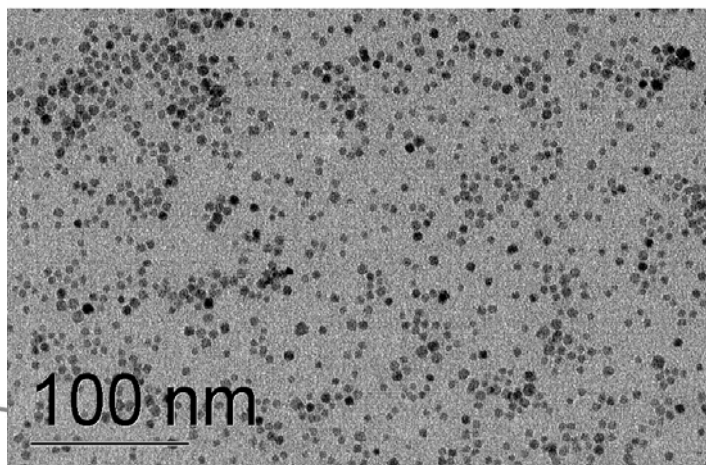

- DMSA-NPs (c) are highly dispersible in solution
- Promote metal preconcentration in complex samples
- DMSA complexes well with proteins for metals
- The metal-bound NPs are collected on surface of electrode (a or b) and voltammetrically detected
- The whole process takes ~ 90s

Example detection of magnetic NP sensors

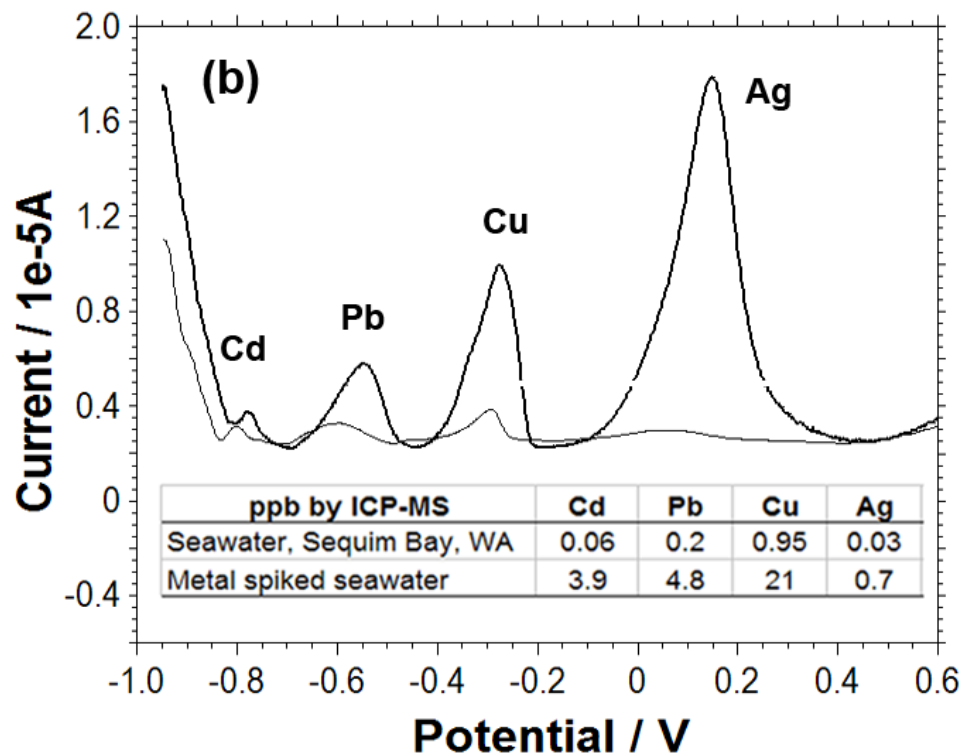

- 0-50 ppb urinary Pb could be quantitatively detected after 2.5 min
- Range is relevant to biomonitoring
- Analysis of 3 unknown urine samples yielded similar values to ICP-MS

- Detection limits of metals in seawater are less than 1 ppb
- Background metals in seawater and river water can be detected
- No sample pre-treatment
- 3 min total analysis time

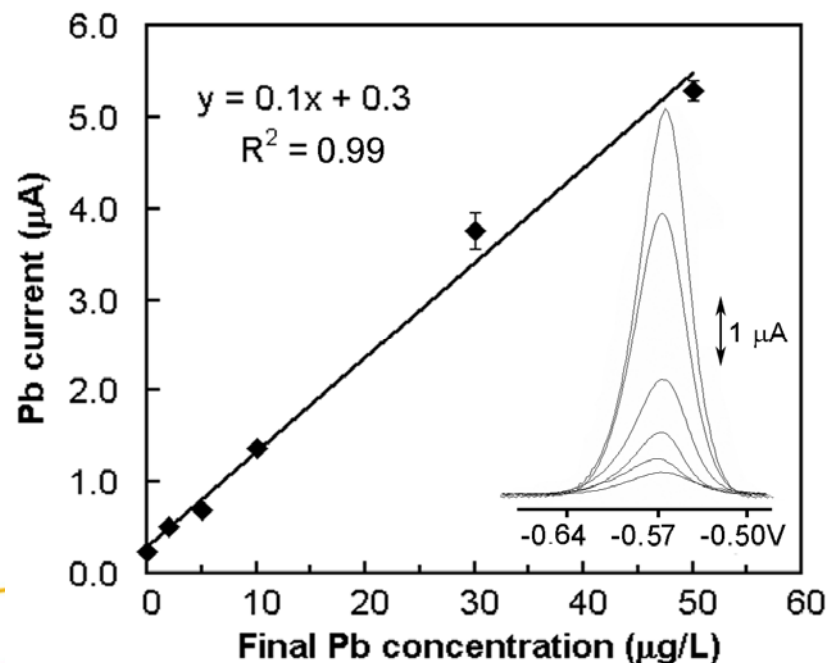

Summary: Two classes of nanomaterials for sensors

	SAMMS	Functional magnetic NPs
Advantage	<ul style="list-style-type: none"> - Withstand wide pH range (pH 0-9) - Small pore size exclude proteins from fouling the binding sites - Easily immobilized on the electrode surface using Nafion - Can be engineered into low-cost, easy to use, disposable strips 	<ul style="list-style-type: none"> - Fully dispersible in solution - Once bound with metals, fast collected on magnetic electrode - Make very sensitive sensor in a short time (LDL < 1ppb in 2 min)
Application	<ul style="list-style-type: none"> - Urinary Pb and Cd detection - Cd, Pb, Cu, Hg, Tl, U, Eu detection in waters - No sample pretreatment - 3-5 min analysis time - < 5% error of 7-9 consecutive measurements of urinary Pb 	<ul style="list-style-type: none"> - Urinary Pb detection - Cd, Pb, Cu, Ag detection in natural waters - No sample pretreatment - 2-3 min analysis time - 5% error of 7 consecutive measurements of urinary Pb
Patent application	"SAMMS-Nafion electrochemical sensor and method for making"	"Functional magnetic nanoparticle analyte sensor"

Prototype device for quantitative metal analysis

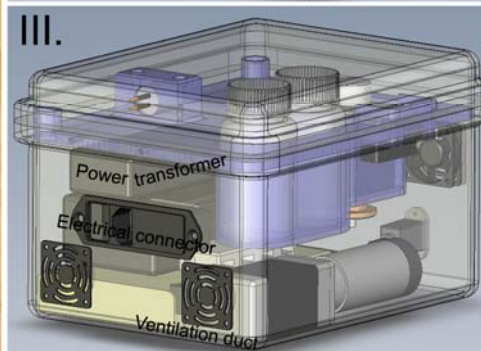
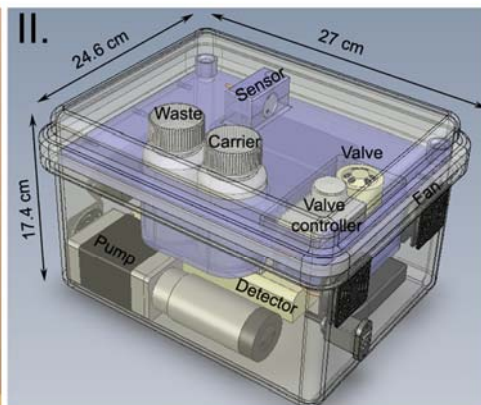

- A bit larger than a lunchbox
- Programmable
- Requires about 1.5 times the power of a typical laptop computer
- \$10K per unit

- Plug-and-play feature allows different sensors to be easily exchanged for detecting a variety of toxins

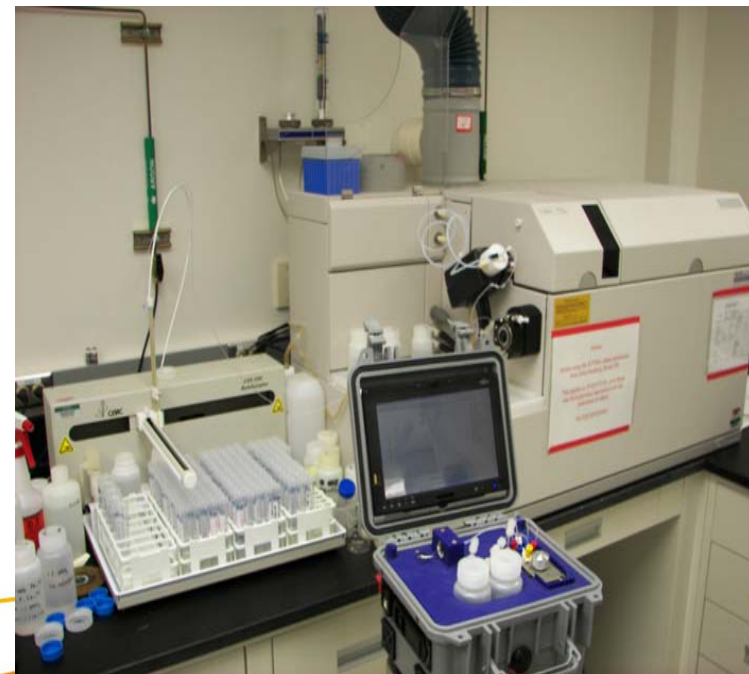

Disposable electrodes as screening tools

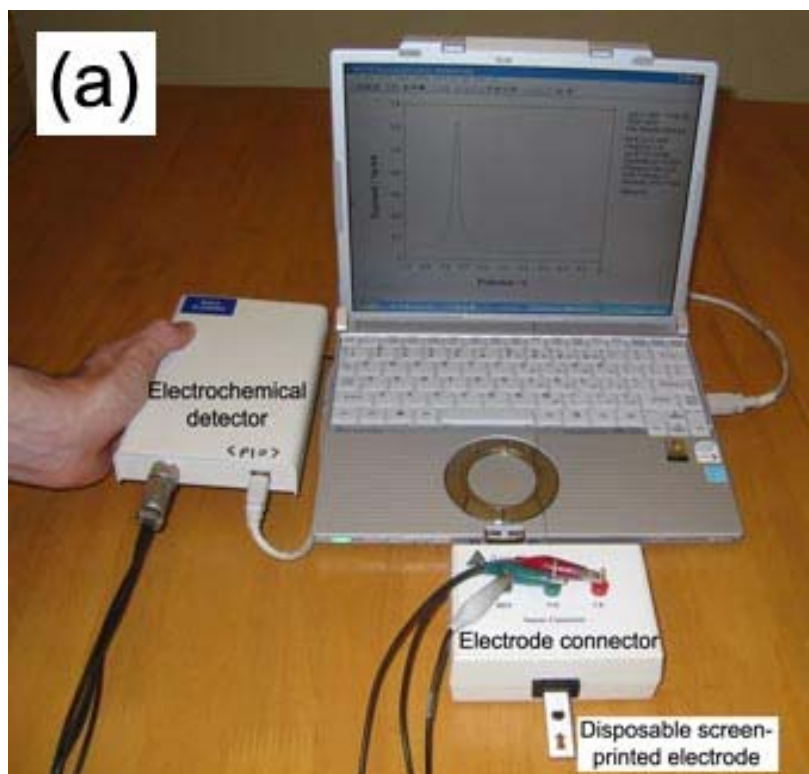

A portable sensor (a) system consisting of a disposable electrode strip (50 cent), a detector, an electrode connector, and a computer; all the components can be integrated into a single device similar to (b) the LeadCare device (ESA Biosciences, Inc.)

Conclusions

- Portable metal sensor systems have been developed with a built-in preconcentration function using advanced nanomaterials (SAMMS and functional magnetic nanoparticles)
- The surface chemistry provides the analytical enhancement
- Two sensor systems: (I) portable analyzers for quantitative analysis and (II) low cost, easy to use disposable sensors for screening test
- Low ppb detections of Cd, Pb, Hg, Cu, Ag, U, Eu, and Tl have been demonstrated
- Measurements are done directly after 2-6 min without sample pretreatment (nor protein fouling) in river water, ground water, seawater, and urine

How our work is viewed:

- ▶ **Prof. Richard Compton of Oxford University, UK,** told *Chemistry World* about our NP sensors (Yantasee et al., *Analyst*, **2008**, 133, 348)

'This is an extremely elegant piece of analytical work, neatly combining surface modification chemistry with magnetic particle separation and sensitive electroanalytical detection.'

'The detection limits are impressive and, in particular, the challenge of working quantitatively on the substrates studied cannot be over-emphasized.'

Toxin test in a lunchbox, James Mitchell Crow, 22 February 2008,
<http://www.rsc.org/chemistryworld/News/2008/February/22020801.asp>

Future work

- Portable Cd and Pb analyzers for worker (urine) and work place monitoring (in air and on surface), which will benefit:
 - routine industrial hygiene air monitoring (must be done by employers as mandated by OSHA)
 - personal air monitoring
 - medical surveillance
 - NIOSH's Health Hazard Evaluation (HHE)
- Portable analyzer for speciated mercury (Hg^{2+} , methyl Hg) in breast milk and blood for Hg biomonitoring (e.g., how Hg transfer from mother to infant)

Acknowledgement

- ▶ CDC/NIOSH, grant # R21 OH008900
- ▶ NIH/NIEHS, grant # R21 ES015620
- ▶ NIH/NIEHS, grant # R01 ES10976
- ▶ DOE-EMSP
- ▶ Work is performed in EMSL, a DOE scientific user facility
- ▶ Staff:
 - K. Hongsirikarn
 - C. Warner
 - M. Warner
 - V. Sukwarotwat
 - K. Pattamakomsan
 - M.B. Toloczko
 - T. Sangvanich
 - G.E. Fryxell
 - J. Davidson
 - D. Choi
 - B. Chanhattakorn
 - R.A. Wiacek
 - C Timchalk
 - W. Chouyyok
 - W. Kiatkittipong
 - R.S. Addleman
 - J. Soelberg
 - Y. Lin

Questions?